

# The Butterscotch Garage Under

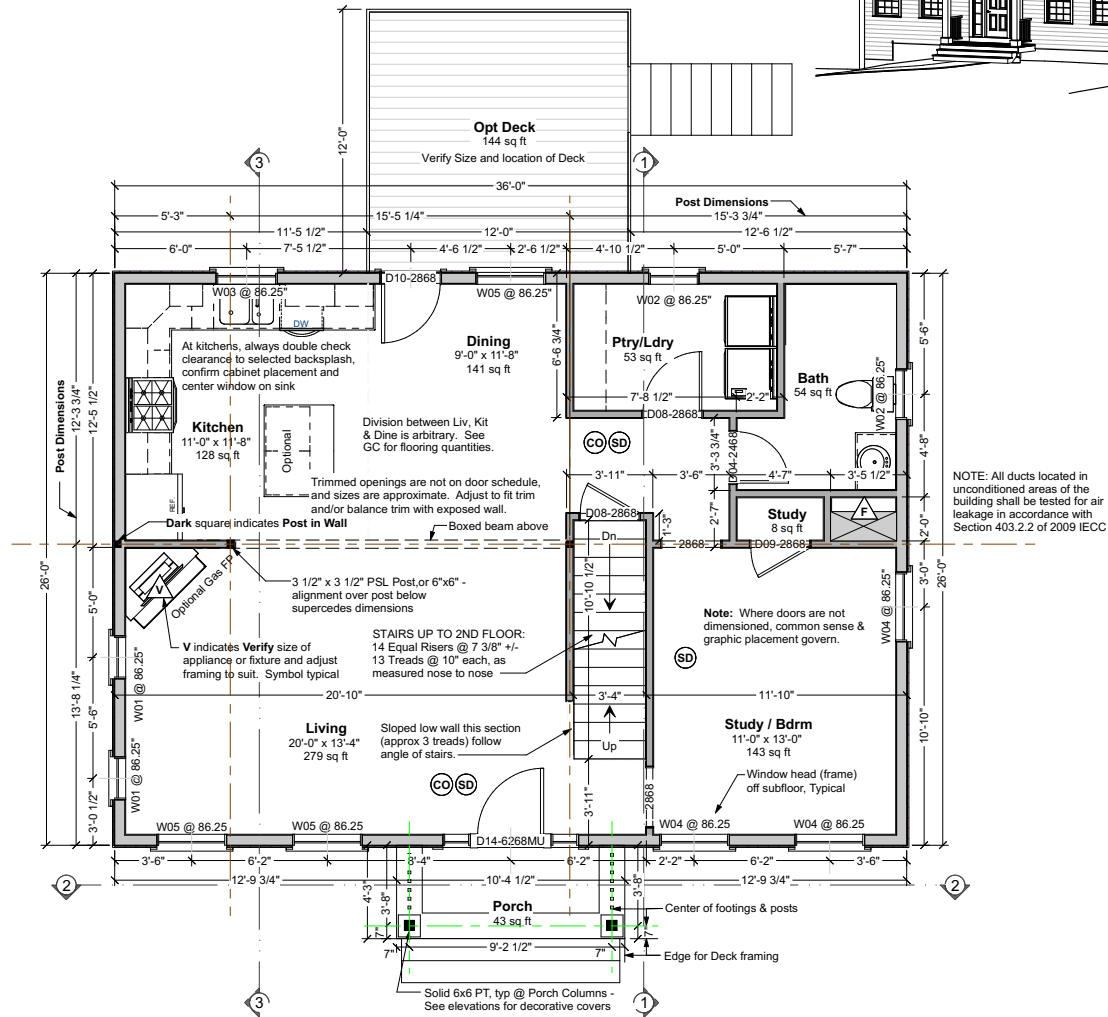

## First Floor Plan



Living Area this Floor: 936 sq ft  
8'-0" Ceiling Height

### NOTE TO HOMEOWNER:

These construction plans ARE NOT a part of your construction contract with your builder, unless your P&S agreement specifies that they are. Your P&S and its attachments (like the builder's specifications or a review set of this design) describes what you and your builder agreed the builder would build for you. We here at Artform Home Plans do not have the

These drawings are intended for use by an experienced professional builder in responsible charge of the entire project, including but not limited to mechanical, electrical and sitework. Any additional adaptation for these trades or other trades must be determined prior to start of construction. Contact Artform for any adjustments needed.

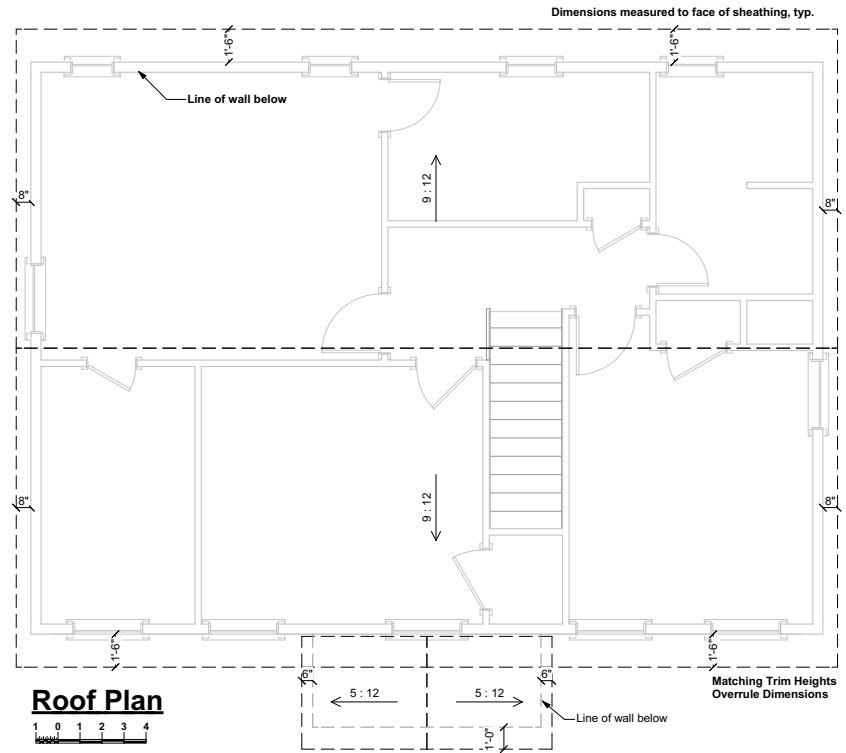
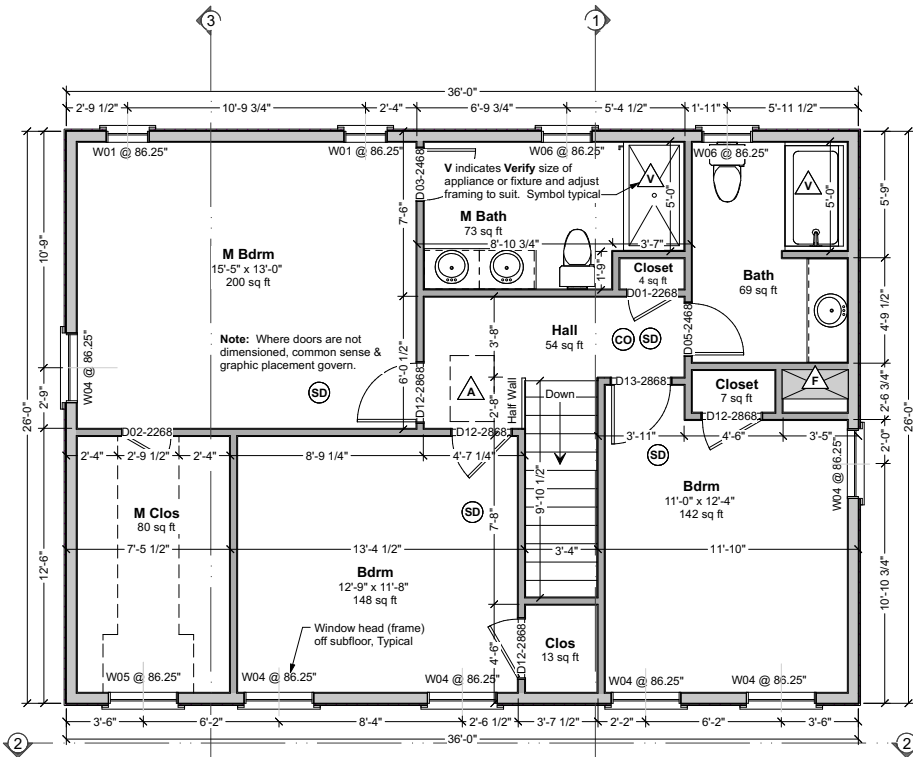

## The Butterscotch Garage Under

# The Butterscotch Garage Under

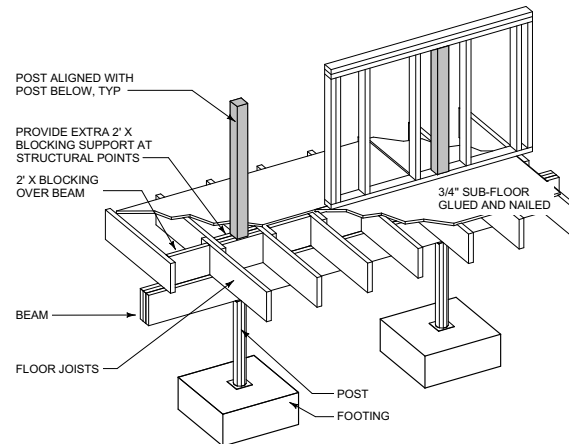
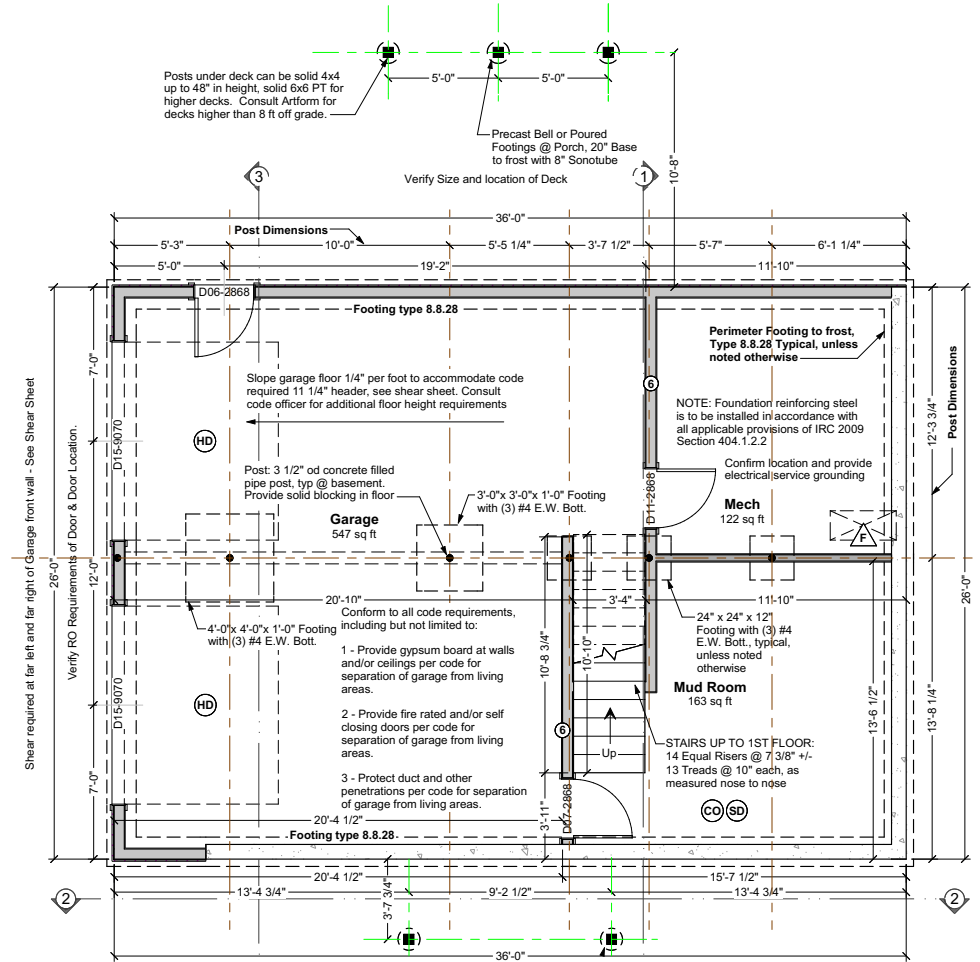

# The Butterscotch Garage Under



**Rear Elevation**

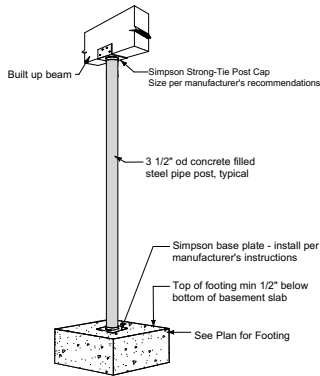

**Typical Basement Post**

Not to Scale

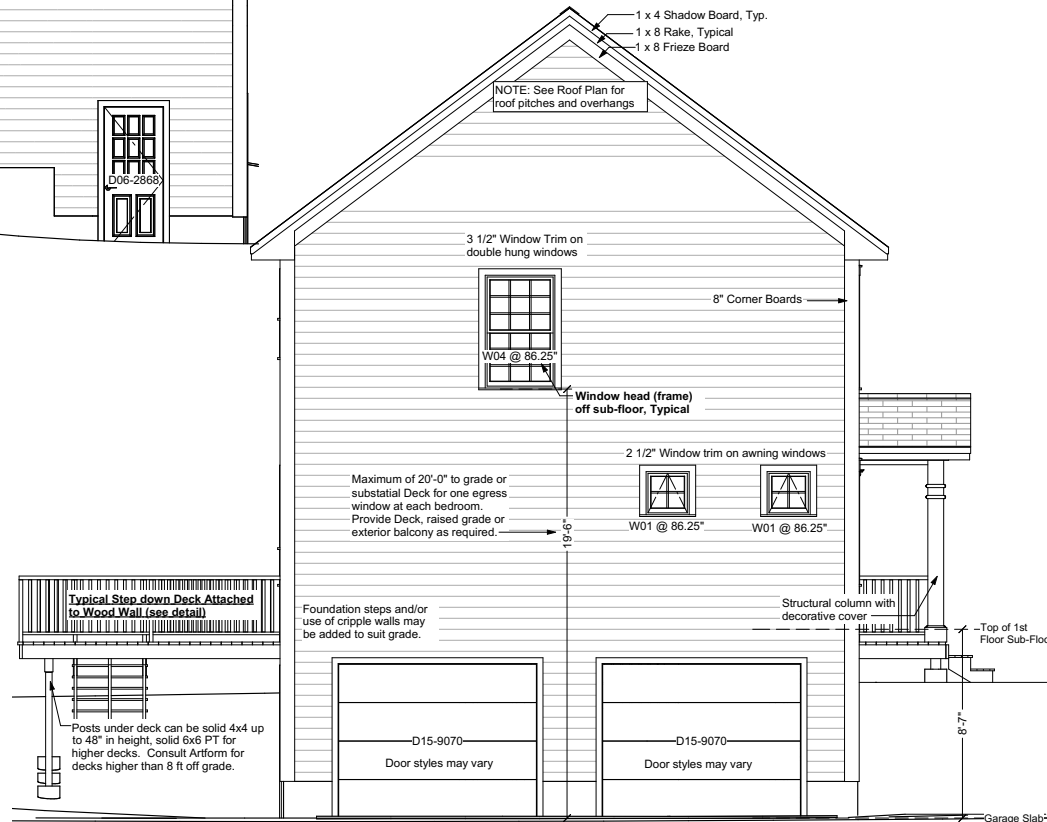

**Left Elevation**

Garage slab height may vary. If garage slab height is lower than shown, consult Ariform for aesthetic direction. Taller garage doors, transoms, lintels and/or additional frieze boards may be required to achieve desired look.